



## OP-MDCX8xxL1SD-80- Tunable

### 10Gb/s Tunable DWDM XFP 80km Transceiver

#### PRODUCT FEATURES

- Supports 9.95Gb/s to 11.3Gb/s bit rates
- Monolithically integrated full C-band tunable transmitter
- 50 GHz ITU channel spacing with integrated wavelength locker
- C-band-tunable Laser and APD receiver
- Maximum link length of 80km
- Full Duplex LC connector
- Hot-pluggable XFP footprint
- Supports Line-side and XFI loopback
- No Reference Clock required
- Built-in digital diagnostic functions
- Standard bail release mechanism
- Power dissipation <2.5W
- Case temperature range:0 °C to 70 °C



## APPLICATIONS

- DWDM 10GBASE-ZR/ZW 10G Ethernet
- DWDM 80KM 10G Fiber Channel
- DWDM SONET OC-192&SDH STM-64

## PRODUCT DESCRIPTION

The tunable 10 Gb/s XFP transceiver is an integrated fiber optic transceiver that provides a high-speed serial link at signaling rates from 9.95 Gb/s to 11.35 Gb/s. The module complies with the 10 Gigabit small form factor pluggable (XFP) multisource agreement-MSA (INF-8077i) and Tunable XFP for ITU Frequency Grid Applications (SFF-8477) .

It complies with the ITU-T G.698.1 standard with 50 GHz channel spacing for SONET/SDH, IEEE DWDM 10GBASE-ZR for 80 km reach (Ethernet), and DWDM 10GFC for 80 km reach (Fiber Channel) applications.

The transceiver integrates the receiver and transmit path on one module. On the transmit side, the 10 Gbps serial data stream is recovered, retimed, and passed to a modulator driver. The modulator driver biases and modulates a C-band-tunable integrated laser Mach-Zehnder (ILMZ), enabling data transmission over single-mode fiber through an industry-standard LC connector. On the receiver side, the 10 Gbps data stream is recovered from an APD/ trans-impedance amplifier, retimed, and passed to an output driver. This module features a hot-pluggable XFI-compliant electrical interface.

OP-DCX8XXL1SD-80-TUNABLE- Wavelength Guide Pin Descriptions

Channel	Wavelength (nm)	Frequency (THZ)	Channel	Wavelength (nm)	Frequency (THZ)
1	1568.77	191.10	52	193.65	1548.11
2	1568.36	191.15	53	193.70	1547.72
3	1567.95	191.20	54	193.75	1547.32
4	1567.54	191.25	55	193.80	1546.92
5	1567.13	191.30	56	193.85	1546.52
6	1566.72	191.35	57	193.90	1546.12
7	1566.31	191.40	58	193.95	1545.72
8	1565.90	191.45	59	194.00	1545.32
9	1565.50	191.50	60	194.05	1544.92



10	1565.09	191.55	61	194.10	1544.53
11	1564.68	191.60	62	194.15	1544.13
12	1564.27	191.65	63	194.20	1543.73
13	1563.86	191.70	64	194.25	1543.33
14	1563.45	191.75	65	194.30	1542.94
15	1563.05	191.80	66	194.35	1542.54
16	1562.64	191.85	67	194.40	1542.14
17	1562.23	191.90	68	194.45	1541.75
18	1561.83	191.95	69	194.50	1541.35
19	1561.42	192.00	70	194.55	1540.95
20	1561.01	192.05	71	194.60	1540.56
21	1560.61	192.10	72	194.65	1540.16
22	1560.20	192.15	73	194.70	1539.77
23	1559.79	192.20	74	194.75	1539.37
24	1559.39	192.25	75	194.80	1538.98
25	1558.98	192.30	76	194.85	1538.58
26	1558.58	192.35	77	194.90	1538.19
27	1558.17	192.40	78	194.95	1537.79
28	1557.77	192.45	79	195.00	1537.40
29	1557.36	192.50	80	195.05	1537.00
30	1556.96	192.55	81	195.10	1536.61
31	1556.55	192.60	82	195.15	1536.22
32	1556.15	192.65	83	195.20	1535.82
33	1555.75	192.70	84	195.25	1535.43
34	1555.34	192.75	85	195.30	1535.04
35	1554.94	192.80	86	195.35	1534.64
36	1554.54	192.85	87	195.40	1534.25
37	1554.13	192.90	88	195.45	1533.86
38	1553.73	192.95	89	195.50	1533.47
39	1553.33	193.00	90	195.55	1533.07
40	1552.93	193.05	91	195.60	1532.68
41	1552.52	193.10	92	195.65	1532.29
42	1552.12	193.15	93	195.70	1531.90
43	1551.72	193.20	94	195.75	1531.51
44	1551.32	193.25	95	195.80	1531.12
45	1550.92	193.30	96	195.85	1530.72
46	1550.52	193.35	97	195.90	1530.33
47	1550.12	193.40	98	195.95	1529.94
48	1549.72	193.45	99	196.00	1529.55
49	1549.32	193.50	100	196.05	1529.16
50	1548.91	193.55	101	196.10	1528.77
51	1548.51	193.60	102	196.15	1528.38

**Note:**

1. When a tunable module is plugged in for the first time, it will go to a default channel, OP-DCX8XXL1SD-80-TUNABLE default channel is 1568.77nm, compatible with channel range from 1 to 102
2. When the module is power cycled it will automatically go to the last channel selected, or when Tx\_Disable asserted and then re-enabled, the module returns to the last channel selected.

## I . Absolute Maximum Ratings

Parameter	Symbol	Min	Typ	Max	Unit	NOTE
Maximum Supply Voltage 1	Vcc3	-0.5		4.0	V	
Maximum Supply Voltage 2	Vcc5	-0.5		6.0	V	
Storage Temperature	Ts	-40		85	°C	
Case Operating Temperature	T <sub>case</sub>	0		70	°C	

## II. Electrical Characteristics

Parameter	Symbol	Min	Typ	Max	Unit	NOTE
Supply Voltage – 1.8V supply	Vcc2	1.71		1.89	V	
Supply Voltage – 3.3V supply	Vcc3	3.13		3.47	V	
Supply Current – 1.8V supply	Icc2			180	mA	
Supply Current – 3.3V supply	Icc3			680	mA	
Module total power	P			2.5	W	1
<b>Transmitter</b>						
Input differential impedance	R <sub>in</sub>		100		Ω	2
Differential data input swing	V <sub>in,pp</sub>	120		820	mV	
Transmit Disable Voltage	V <sub>D</sub>	2.0		V <sub>cc</sub>	V	
Transmit Enable Voltage	V <sub>EN</sub>	GND		GND+ 0.8	V	
<b>Receiver</b>						
Differential data output swing	V <sub>out,pp</sub>	340	650	850	mV	3
LOS Fault	V <sub>LOS fault</sub>	V <sub>cc</sub> – 0.5		V <sub>ccHOST</sub>	V	4
LOS Normal	V <sub>LOS norm</sub>	GND		GND+0.5	V	4

**Notes:**

1. Maximum total power value is specified across the full temperature and voltage range.
2. After internal AC coupling.
3. Into 100 ohms differential termination.
4. Loss Of Signal is open collector to be pulled up with a 4.7k – 10kohm resistor to 3.15 – 3.6V. Logic 0 indicates normal operation; logic 1 indicates no signal detected.

### III. Optical Characteristics

Parameter	Symbol	Min	Typ	Max	Unit	NOTE
<b>Transmitter</b>						
Average Optical Power	P <sub>f</sub>	-1		3	dBm	
Wavelength range		1528.38		1568.77	nm	
Optical Wavelength	$\lambda_c$	$\lambda_c - 0.05$		$\lambda_c + 0.05$	nm	
Center Wavelength Spacing			50		GHz	1
Frequency stability (BOL)		$f_c - 1.5$		$f_c + 1.5$	GHz	2
Frequency stability (EOL)		$f_c - 2.5$		$f_c + 2.5$	GHz	2
Side mode Suppression ratio	SMSR	30			dB	
Optical Extinction Ratio	ER	9			dB	
Transmitter and Dispersion Penalty	TDP			3	dB	
Average Launch power of OFF transmitter	P <sub>OFF</sub>			-30	dBm	
<b>Receiver</b>						
Rx Sensitivity	R <sub>SENS</sub>			-24	dBm	Back to back ,3
				-21	dBm	Fiber(-300 to 1450ps/nm)
Input Saturation Power (Overload)	P <sub>sat</sub>	-7			dBm	
Wavelength Range	$\lambda_c$	1260		1600	nm	
Receiver Reflectance	R <sub>rx</sub>			-27	dB	
LOS De-Assert	LOS <sub>D</sub>			-27	dBm	
LOS Assert	LOS <sub>A</sub>	-37			dBm	
LOS Hysteresis		0.5			dB	

Notes:

1. Corresponds to approximately 0.4 nm.
2.  $f_c$  refer to Page 2 the Frequency row of OP-DCX8XXL1SD-80-TUNABLE Wavelength Guide Table, and test condition is reflect power to transmitter lower than -27dBm.
3. Measured with worst ER; BER < 10<sup>-12</sup> with 10.3Gbps, 2<sup>31</sup> - 1 PRBS.

### IV. Timing Parameters

Parameter	Symbol	Min	Typ	Max	Unit	NOTE
Time to initialize cooled module	T <sub>start_up</sub>			20	S	
Channel Switch time	T <sub>channelSwitch</sub>			200	ms	Any channel to any channel

### V. Pin Assignment

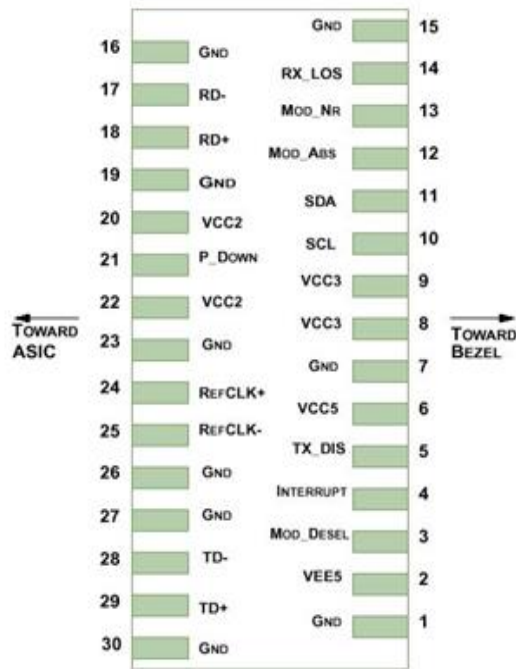

Diagram of Host Board Connector Block Pin Numbers and Name

Pin	Logic	Symbol	Name/Description	NOTE
1		GND	Module Ground	1
2		VEE5	Optional -5.2 Power Supply – Not required	
3	LVTTL-I	Mod-Desel	Module De-select; When held low allows the module to respond to 2-wire serial interface commands	
4	LVTTL-O	Interrupt	Interrupt (bar); Indicates presence of an important condition which can be read over the serial 2-wire interface	2
5	LVTTL-I	TX_DIS	Transmitter Disable; Transmitter laser source turned off	
6		VCC5	+5 Power Supply	
7		GND	Module Ground	1
8		VCC3	+3.3V Power Supply	
9		VCC3	+3.3V Power Supply	
10	LVTTL-I	SCL	Serial 2-wire interface clock	2
11	LVTTLI/O	SDA	Serial 2-wire interface data line	2
12	LVTTL-O	Mod_Abs	Module Absent; Indicates module is not present. Grounded in the module.	2
13	LVTTL-O	Mod_NR	Module Not Ready; XGIGA defines it as a logical OR between RX_LOS and Loss of Lock in TX/RX.	2
14	LVTTL-O	RX_LOS	Receiver Loss of Signal indicator	2
15		GND	Module Ground	1
16		GND	Module Ground	1
17	CML-O	RD-	Receiver inverted data output	
18	CML-O	RD+	Receiver non-inverted data output	
19		GND	Module Ground	1
20		VCC2	+1.8V Power Supply – Not required	

21	LVTTTL-I	P_Down/RST	Power Down; When high, places the module in the low power stand-by mode and on the falling edge of P_Down initiates a module reset	
			Reset; The falling edge initiates a complete reset of the module including the 2-wire serial interface, equivalent to a power cycle.	
22		VCC2	+1.8V Power Supply – Not required	
23		GND	Module Ground	1
24	PECL-I	RefCLK+	Reference Clock non-inverted input, AC coupled on the host board – Not required	3
25	PECL-I	RefCLK-	Reference Clock inverted input, AC coupled on the host board – Not required	3
26		GND	Module Ground	1
27		GND	Module Ground	1
28	CML-I	TD-	Transmitter inverted data input	
29	CML-I	TD+	Transmitter non-inverted data input	
30		GND	Module Ground	1

Notes:

1. Module circuit ground is isolated from module chassis ground within the module.
2. 2 Open collector; should be pulled up with 4.7k – 10kohms on host board to a voltage between 3.15V and 3.6V.
3. A Reference Clock input is not required by the XFP 80km tunable. If present, it will be ignored.

## VI.Digital Diagnostic Functions

As defined by the XFP MSA, XFP 80km tunable transceivers provide digital diagnostic functions via a 2-wire serial interface, which allows real-time access to the following operating parameters:

- Transceiver temperature
- Laser bias current
- Transmitted optical power
- Received optical power
- Transceiver supply voltage

It also provides a sophisticated system of alarm and warning flags, which may be used to alert end-users when particular operating parameters are outside of a factory-set normal range.

The operating and diagnostics information is monitored and reported by a Digital Diagnostics Transceiver Controller inside the transceiver, which is accessed through the 2-wire serial interface. When the serial protocol is activated, the serial clock signal (SCL pin) is generated by the host. The positive edge clocks data into the XFP transceiver into those segments of its memory map that are not write-protected. The negative edge clocks data from the XFP transceiver. The serial data signal (SDA pin) is bi-directional for

serial data transfer. The host uses SDA in conjunction with SCL to mark the start and end of serial protocol activation. The memories are organized as a series of 8-bit data words that can be addressed individually or sequentially. The 2-wire serial interface provides sequential or random access to the 8 bit parameters, addressed from 000h to the maximum address of the memory.

For more detailed information including memory map definitions, please see the XFP MSA Specification.

## VII. Mechanical Specifications

XFP transceivers are compliant with the dimensions defined by the XFP Multi-Sourcing Agreement (MSA).

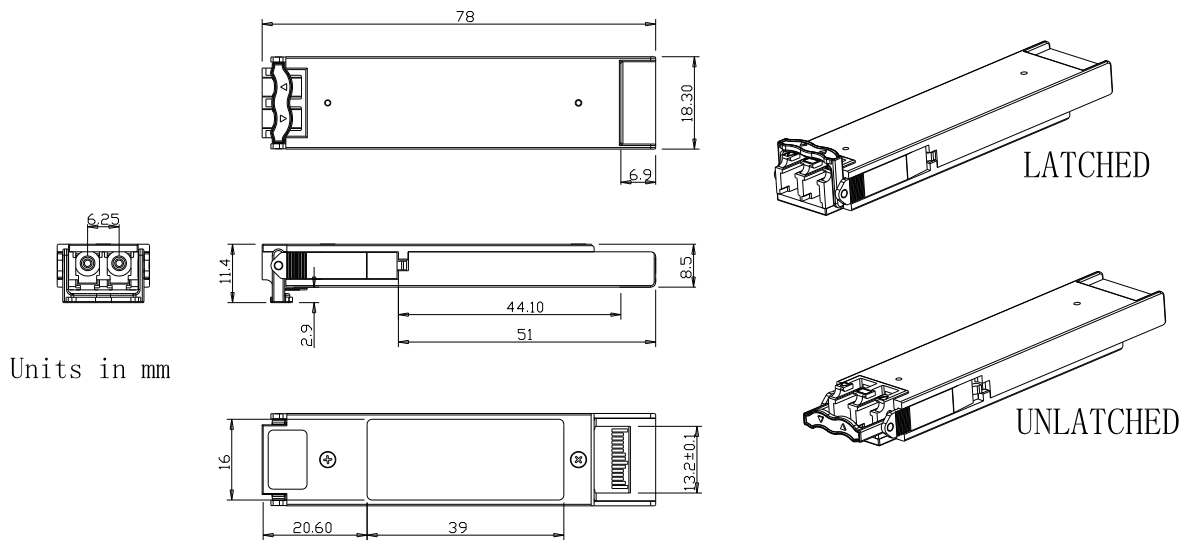

XFP Transceiver (dimensions are in mm)



### VIII. PCB Layout and Bezel Recommendations

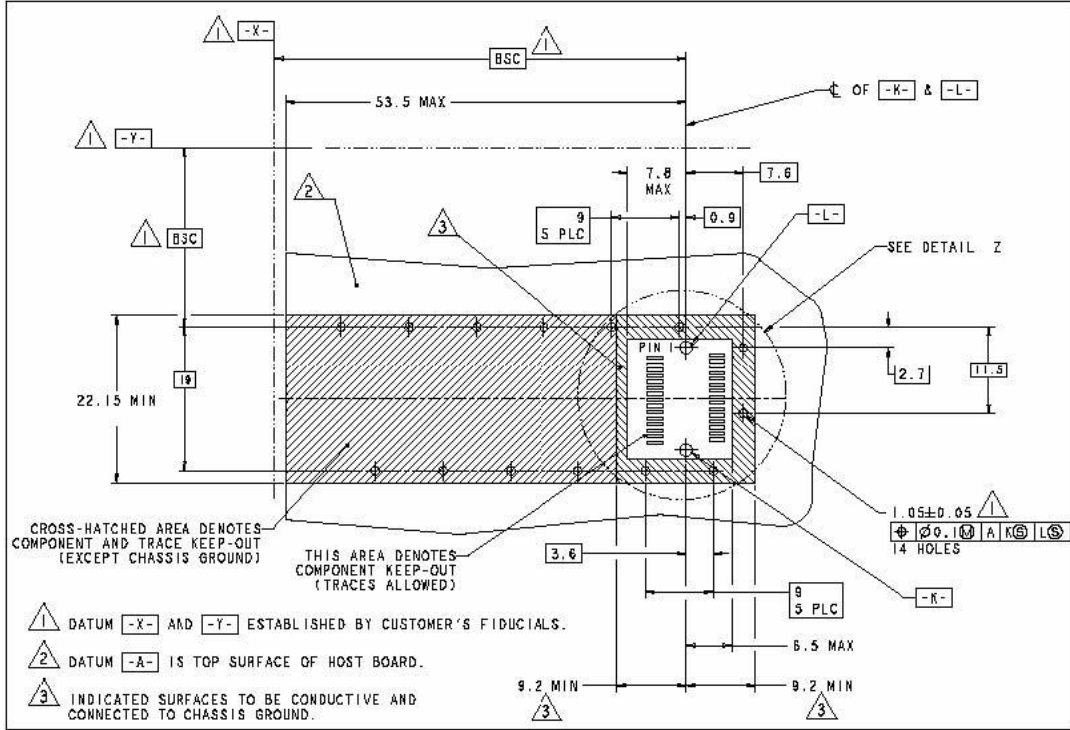

**XFP Host Board Mechanical Layout (dimensions are in mm)**

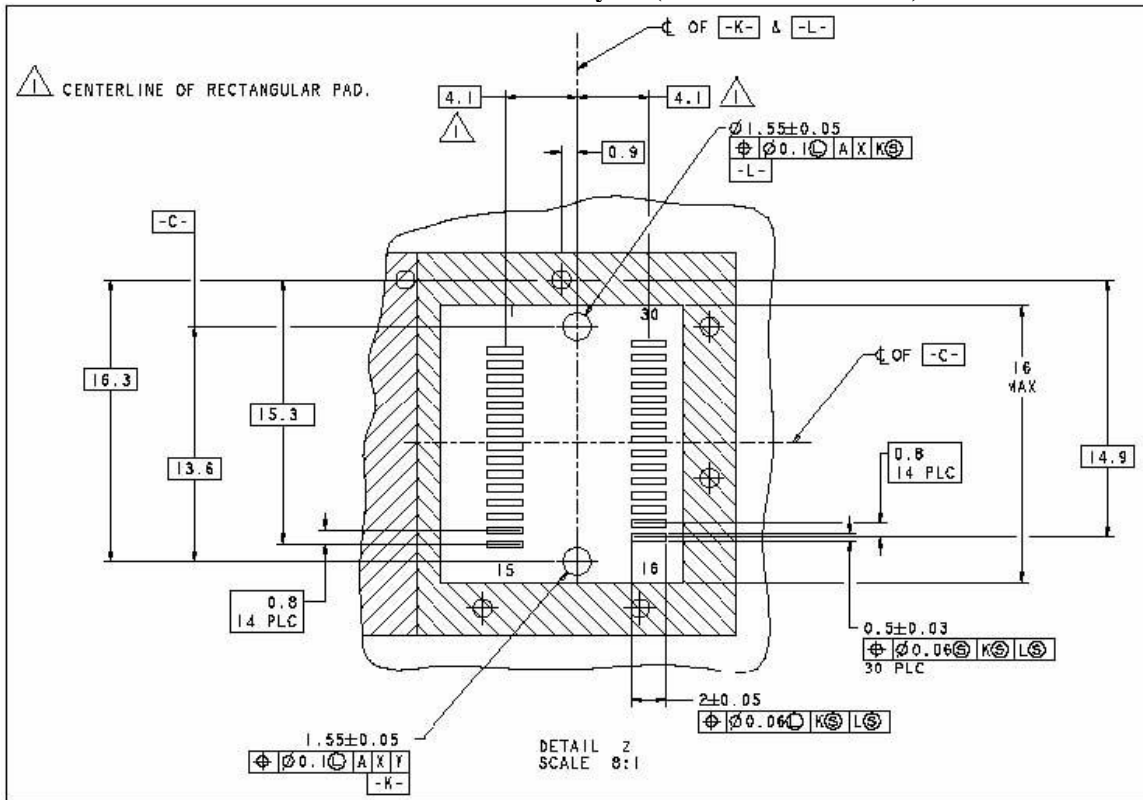

**XFP Detail Host Board Mechanical Layout (dimensions are in mm)**

### Appendix A. Document Revision

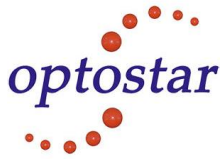

Version No.	Date	Description
1.0	2013-08-26	Preliminary datasheet
2.0	2016-03-14	Update two channel types to one type: OP-DCX8XXL1SD-80-TUNABLE (88 channels)
3.0	2016-08-17	Update channel number from 88 to 102